

RING

E-VEHICLES
CATALOGUE
2021



RING



RING
CENTER

Fitness
Wellness

RING GYM

RING

RING SPORT was founded in 1993 as one of the first fitness and home workout equipment importers, and in the following decades became regional market leader.

RING SPORT equipment has definitely the best quality-to-price ratio regionally. With more than 23 years of market presence, our brand is sold within more than 300 points of sale in 7 countries.

In 2016, we introduced electric scooters and electric bikes in our portfolio. Our products are designed by certified engineers and sportsmen at the same time, to increase maximum endurance, quality and performance. Direct result is increased use of RING e-vehicles on our market's streets.

We are committed to highest quality standards, through the attention to detail in design and production processes, where at the same time we're assuring the most competitive market price. All of our e-vehicles have all the required certificates, which also represent our quality warranty.

Our products are even globally well recognized and we are very proud that we're present in many multibrand sports stores and on leading online shops within the region.



RING

Electric scooter

RX Z1

RX Z1 **Electric scooter**

- Color: black
- Material: Aerospace grade aluminum
- Wheel size: 6,5" solid tire
- Motor power: 250W
- Computer: displaying speed and battery charge level
- Max speed: 25 km/h
- Drive autonomy: 14 km depending on drive conditions
- Battery capacity: 24V/ 6Ah Li-ion
- Battery charge time: 4-4,5h
- Front brake: ABS (anti-block system)
- Rear brake: mechanical disc brake
- Water resistance: IP54
- Shock absorbers: front
- Max load capacity: 100kg on mainly flat terrains
- Curb weight: 9,1 kg



RING

Electric scooter

RX1



**NEW
DESIGN!**



APP Mini Robot



RX1 Electric scooter

- Color: black
- Material: Aerospace grade aluminum
- Wheel size: 8,5" inflatable tire
- Motor power: 300W
- Max speed: 25 km/h (common mode), 15 km/h (energy saving mode)
- Computer: displaying speed and battery charge level
- Mini robot app: e-scooter performance control
- Drive autonomy: 15 km
- Battery capacity: 36V/ 4,4 Ah Li-ion / charging time 4-4,5 h
- Brakes: front ABS (anti-block system) and rear mechanical disc brake
- Incline level: up to 15°
- Water resistance: IP54
- Shock absorbers: front
- Max load capacity: 120kg on mainly flat terrains
- Dimensions when assembled: 108 x 43 x 114 cm
- Dimensions when folded: 108 x 43 x 49 cm
- Curb weight: 12,5 kg





RING

Electric scooter
RX2

RX2 black **Electric scooter**

- Color: black
- Material: Aerospace grade aluminum
- Wheel size: 8,5" inflatable tire
- Motor power: 300W
- Max speed: 25 km/h (common mode), 15 km/h (energy saving mode)
- Computer: displaying speed, battery level and driving mode
- Mini robot app: e-scooter performance control
- Drive autonomy: 20 km
- Battery capacity: 36V/ 6,6 Ah Li-ion / charging time 4-4,5 h
- Brakes: front ABS (anti-block system) and rear mechanical disc brake
- Incline level: up to 15°
- Water resistance: IP54
- Max load capacity: 120kg on mainly flat terrains
- Dimensions when assembled: 108 x 43 x 114 cm
- Dimensions when folded: 108 x 43 x 49 cm
- Curb weight: 12,5 kg

**NEW
DESIGN!**



APP Mini Robot



RING

Electric scooter

RX2



**NEW
DESIGN!**

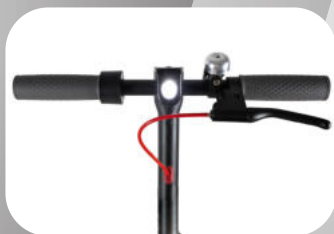

RX2 white Electric scooter

- Color: white
- Material: Aerospace grade aluminum
- Wheel size: 8,5" inflatable tire
- Motor power: 300W
- Max speed: 25 km/h (common mode), 15 km/h (energy saving mode)
- Computer: displaying speed, battery level and driving mode
- Mini robot app: e-scooter performance control
- Drive autonomy: 20 km
- Battery capacity: 36V/ 6,6 Ah Li-ion / charging time 4-4,5 h
- Brakes: front ABS (anti-block system) and rear mechanical disc brake
- Incline level: up to 15°
- Water resistance: IP54
- Max load capacity: 120kg on mainly flat terrains
- Dimensions when assembled: 108 x 43 x 114 cm
- Dimensions when folded: 108 x 43 x 49 cm
- Curb weight: 12,5 kg

APP Mini Robot



RING

Electric scooter

RX3

RX3 black Electric scooter

- Color: black
- Material: Aerospace grade aluminum
- Wheel size: 8,5" inflatable tire
- Motor power: 300W
- Max speed: 25 km/h (common mode), 15 km/h (energy saving mode)
- Computer: displaying speed, battery level and driving mode
- Mini robot app: e-scooter performance control
- Drive autonomy: up to 30 km depending on drive conditions (weight, temperature, driving style)
- Battery capacity: 36V/ 10 Ah Li-ion / charging time 4-4,5 h
- Brakes: front ABS (anti-block system) and rear mechanical disc brake
- Incline level: up to 15°
- Water resistance: IP54
- Max load capacity: 120kg on mainly flat terrains
- Dimensions when assembled: 108 x 43 x 114 cm
- Dimensions when folded: 108 x 43 x 49 cm
- Curb weight: 12,5 kg

APP Mini Robot



NEW
DESIGN!



RING

Electric scooter

RX8

RX8 plus

**EASY BATTERY
REPLACEMENT!**



RX8 / RX8 plus Electric scooter - black

Dimensions when assembled: 1056x420x1166 mm

Dimensions when folded: 1056x420x450 mm

Max drive autonomy (RX8): up to 20 km depending on driving conditions

Max drive autonomy (RX8 plus): up to 25 km depending on driving conditions

Max speed: 32 km/h

Tire dimensions: 8,5" vacuum tire

Computer: displaying speed, battery charge level and driving mode

Net curb weight: around 12,5 kg

Color: black with red rubber details (RX8);

black with blue rubber details (RX8 plus)

Frame material: Aerospace grade aluminum

Motor power: 350W

Battery capacity: 36 V/5 Ah replaceable

Battery capacity RX8 plus: 36V/6,4 Ah Panasonic replaceable

Front light: LED extra bright

Rear light: LED

Brakes: triple braking system

Charger details: DC 42V / 2 A

Engine propulsion: front wheel drive

Incline level: 15°

Pedal width: 150 mm

Ground-to-pedal height: 145 mm

Ground-to-pedal chassis height: 133 mm

Folding method: One move fold

Battery replacement mode: Self-lock hinge

Water resistance level: IP54

Battery charging time: 2-3 h

Recommended driver height: 120 - 200 cm

Max load capacity: 20 - 120 kg

Additional weight: up to 10 kg



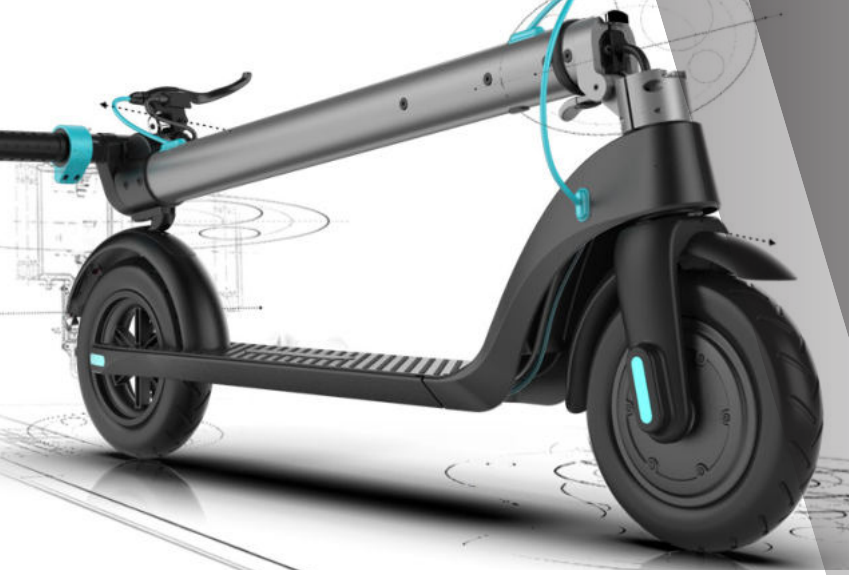

RING

Electric scooter

RX8

RX8 silver Electric scooter

Dimensions when assembled: 1056x420x1166 mm

Dimensions when folded: 1056x420x450 mm

Max drive autonomy: up to 20 km

Max speed: 32 km/h

Tire dimensions: 8,5" vacuum tire

Computer: displaying speed, battery charge level and driving mode

Net curb weight: around 12,5 kg

Frame material: Aerospace grade aluminum

Motor power: 350W

Battery capacity: 5Ah / 6,4Ah optional 36V

Front light: LED extra bright

Rear light: LED

Brakes: triple braking system

Charger details: DC 42V / 2 A

Engine propulsion: front wheel drive

Incline level: 15°

Pedal width: 150 mm

Ground-to-pedal height: 145 mm

Ground-to-pedal chassis height: 133 mm

Folding method: One move fold

Battery replacement mode: Self-lock hinge

Water resistance level: IP54

Battery charging time: 2-3 h

Recommended driver height: 120 - 200 cm

Max load capacity: 20 - 120 kg

Additional weight: up to 10 kg



**EASY BATTERY
REPLACEMENT!**

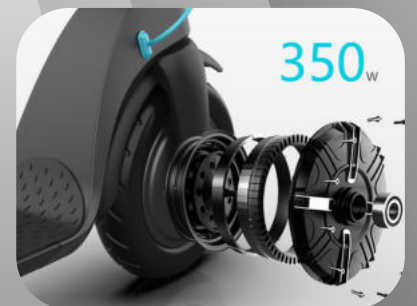
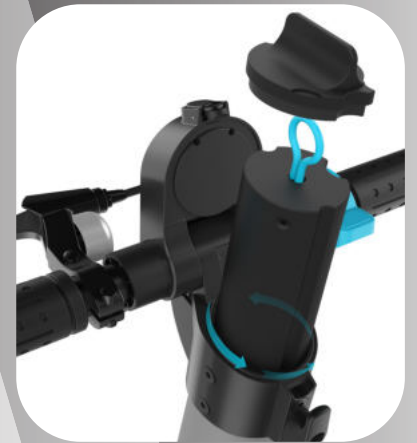

RING

Electric scooter

RX11

RX11 max

**EASY BATTERY
REPLACEMENT!**

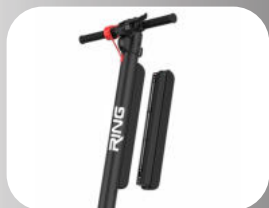

RX11 / RX11 max Electric scooter - black

Dimensions when assembled: 1056x420x1166 mm

Dimensions when folded: 1056x420x450 mm

Max drive autonomy (RX11): up to 30 km depending on driving conditions

Max drive autonomy (RX11 max): up to 40 km depending on driving conditions

Max speed: 30 km/h

Tire dimensions: 10" vacuum tire

Computer: displaying speed, battery charge level and driving mode

Net curb weight: around 16,5 kg

Frame material: Aerospace grade aluminum

Color: black with blue rubber details (RX11);

black with red rubber details (RX11 max)

Motor power: 350W

Battery capacity RX11: 36 V/10 Ah replaceable

Battery capacity RX11 max: 36V/12,8 Ah

Panasonic replaceable

Front light: LED

Rear light: LED

Brakes: triple DISC braking system

Charger details: DC 42V / 2 A

Engine propulsion: front wheel drive

Incline level: 15°

Pedal width: 150 mm

Ground-to-pedal height: 145 mm

Ground-to-pedal chassis height: 133 mm

Folding method: One move fold

Battery replacement mode: Self-lock hinge

Water resistance level: IP54

Battery charging time: 2-3 h

Recommended driver height: 120 - 200 cm

Max load capacity: 20 - 120 kg

Additional weight: up to 10 kg



RING

Accessories



RX ES2

Hook for bag for e-scooters and e-bikes

- Material: built from high quality, resistant polymer, durable and hard.
- The hook is compatible with RING RX1, RX2, Urban, Xiaomi Mijia M365 and M187
- The hook can be used to hook bags, water containers, baskets, helmets etc.



RX ES4

Side mirrors for e-scooters and e-bikes

- Materials: mirror holder and back lid are built from high quality, ultra strong and lightweight polymer, very durable and practical.
- Mirror is flat, it does not deform the image and makes the vision clear.
- Can be adjusted - 360° motion ability makes it easily adjustable for every position.



RX H1 black

E-scooters, e-bikes and skateboards helmet

- Built from high quality ABS polymer
- Inside of the helmet is coated with high quality EPS foam to enhance protections against shocks and high impact
- Comfortable: classic helmet with 11 air openings for cooling and comfortability
- Adjustable: the helmet is equipped with belt fasteners for flexible adjustments
 - Moder design, mate black color with white details



RX ES1

Bag for e-scooter and e-bike

- It can be used with models RING RX1, RX2, URBAN, XiaoMi Mijia M365 / M365 Pro
- The bag was built from practical and ultra resistant 600D nylon fiber, inner polyester EVA makes it composite, it easily maintains the form, it is moisture resistant and very durable.
- It is suitable to pack your scooter charger, mobile phone, safety light, repair kit and other necessary self-aid kits, notebooks, sunglasses etc.



RX ES3

Mobile phone holders for e-scooters and e-bikes

- Phone holder has 4 clamps for tight attachment of all of four phone edges against the e-scooter / e-bike korman
- It's thicker than the most of easy-braking silicon-made phone bike holders, which results in longer life span.
- It is shock-resistant and it has universal attachment hinge: this phone holder is designed for bumpy roads at high speed. It has been tested on various tracks.
- THE HOLDER IS UNIVERSAL FOR ALL MOBILE PHONE MODELS



RX ES5

Child handrails for e-scooter

- GREAT FOR CHILD PROTECTION: if you drive together with your child, original korman is too high; handrail for your child is adjustable according to it's height and provides better security.
- COMFORTABLE: child handrails are built from silicone, anti-slip material, easy to grip and hold during the drive
- EASY TO ATTACH: handrails are very easy to attach and remove without damaging the e-scooter; screws set is included with the handrails; height is adjustable according to your child's height.
 - Length: 22,5 cm

RING

Electric bike

RX20



RX20 Shimano Electric foldable bike

Wheel size: 20"

Curb weight: 20kg

Max load capacity: 130 kg

Motor power: 250W / 36V brushless, situated on rear wheel

Battery: Li Ion 36V 8Ah

Battery description: easy replaceable, within the bike frame

Charging time: 3-4 h

Max speed: 25km/h limited by the Law

Drive autonomy: 20-30km

Frame material: Aluminum 6061

Folding: YES

Display: LED in color

Gear shifter: 6 speed Shimano Tourney ARDTZ50GSDT

Shifter handle: Sjhimano ASLTX30R

Brakes front / back: Disc brakes with calipers

Tires: 20x1,95 inflatable

Pedals: PVC foldable

Lights front / back: LED

Color: mate black

Certificates: CE, RoHS

Packaging dimensions: 88x41x71



RING

Electric bike

RX20F



RX20F Shimano Electric foldable bike

Wheel size: 20"

Tire dimensions: 20x4.0

Curb weight: 29kg

Max load capacity: 130 kg

Motor power: 250W brushless, situated on rear wheel

Battery: Li Ion 48V 8Ah

Battery description: easy replaceable, within the bike frame

Charging time: 3-4 h

Max speed: 25km/h limited by the Law

Drive autonomy: up to 25 km

Frame material and dimensions: Aluminum 6061 20"

Folding: YES

Display: LED monochromatic

Gear shifter: 6 speed Shimano Tourney ARDTZ50GSDT

Shifter handle: Shimano ASLTX30R

Brakes front / back: Disc brakes with calipers

Pedals: PVC foldable

Lights front / back: LED

Color: black or turquoise

Certificates: CE, RoHS

Packaging dimensions: 99x50x75

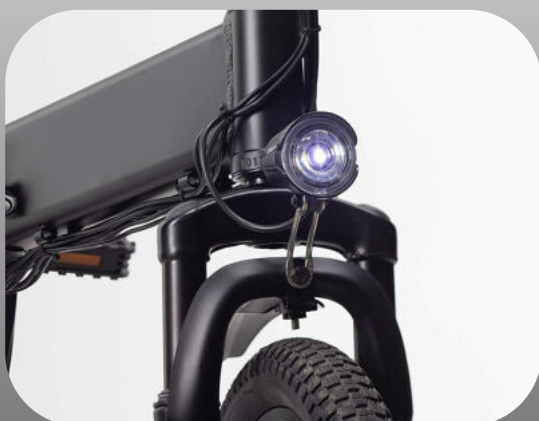

RING

Electric bike

RX25



RX25 Shimano Electric foldable bike

Wheel size: 26"

Tire dimensions: 26x1,95

Curb weight: 31kg

Max load capacity: 130 kg

Motor power: 250W brushless, situated on rear wheel

Battery: Li Ion 36V / 8Ah

Battery description: easy replaceable, within the bike frame

Charging time: 3-4 h

Max speed: 25km/h limited by the Law

Drive autonomy: up to 25 km

Frame material and size: Aluminum 6061 26"

Folding: YES

Display: LED monochromatic

Gear shifter: 6 speed Shimano Tourney ARDTZ50GSDT

Shifter handle: Sjhimano ASLTX30R

Brakes front / back: Disc brakes with calipers

Pedals: PVC foldable

Lights front / back: LED

Color: black or turquoise

Certificates: CE, RoHS

Packaging dimensions: 153x34x80

